

SHENZHEN ATTEN TECHNOLOGY CO., LTD.

- Single soldering iron
- Constant temperature electric soldering stations
- Hot air desoldering station
- Versatile maintenance system
- BGA reworking station
- DC voltage-stabilized power
- DC switching power
- Programmable power

ATTEN

MS-900

4 in 1 Rework Station

User Manual in English

SHENZHEN ATTEN TECHNOLOGY CO., LTD.

Address: Floor 8, Building 2, Senyang High Tech Park, 7th Rd,
Guangming New District, Shenzhen, Guangdong

Tel.: 0755-8602 1389

Fax: 0755-8602 1365 Postcode: 518132

Website: www.atten.com.cn (in Chinese)

www.atten.com (in English)

Email: sales@atten.com.cn

Facebook: <https://www.facebook.com/attencn/>

Engineer's partner

All Copyright Reserved
MADE IN CHINA

CBN030501 (D)

Product warranty

- Since the date of purchase of the product, we provide the purchaser with two years' quality warranty (only for the main unit), and will provide free maintenance services for any failure of the product occurred during normal use of the product within the warranty period due to product defects.
- For products not covered by the quality warranty, we will provide maintenance services for the entire life span of the product.
- If the product user privately modifies any part of the product or improperly uses the product, which results in damage of the product, we will only offer limited maintenance service.
- In case of product failure, please send the product to designated maintenance offices or local agent for repair and maintenance. We strictly prohibit non-authorized maintenance companies and persons from maintaining and repairing the product.

After-sale contact

Contact number of our after-sale service department: (+86) 0755-8602 1266.

Warranty Card

The product's warranty period is valid within two years following the date of purchase. For product problems due to quality defects, we will provide maintenance and repair without charge, provided that the purchase shall provide this card and the purchase receipt. Once we receive the returned product, we will repair the product in two working days and then send the product to the customer. Note: Upon return and repair of the product, please provide the warranty card, otherwise free maintenance service will not be available, thanks for your cooperation!

Product qualification certificate

Product model: _____ Product No.: _____
Inspector: _____ Ex-factory date: _____
Sales clerk: _____ Date of sale: _____

Exploded view of the Upper cover assembly

| | |
|------------|---------------|
| 4 | PM4X15 |
| 3 | Grip strap |
| 2 | Grip buckle |
| 1 | Upper cover |
| Serial No. | Material name |

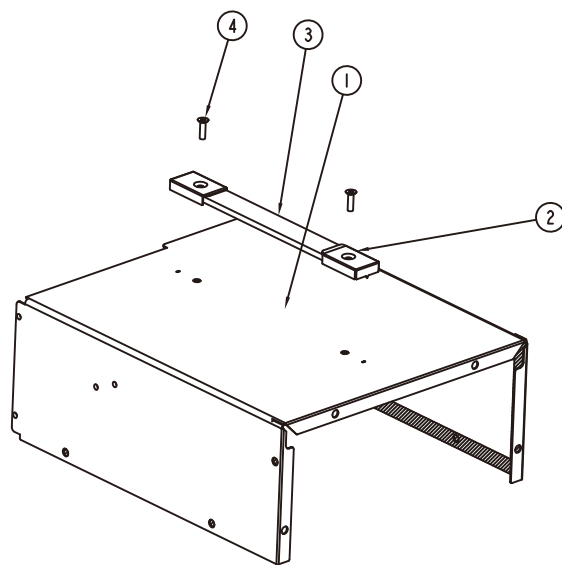

Contents

| | |
|---|----|
| Copyright Information | 2 |
| Description of Common Symbols | 2 |
| Essentials for Users | 2 |
| Safety Cautions | 2 |
| Disclaimer | 2 |
| Packing List | 3 |
| Product Overview | 3 |
| Functional Features | 3 |
| Specifications and Parameters | 4 |
| Tool Kit Diagram | 4 |
| Front Panel Interface Diagram | 5 |
| Rear Panel Interface Diagram | 5 |
| Work Interface Description..... | 5 |
| Working Interface Introduction and Operation Method | 6 |
| System Function Setting | 9 |
| Main Unit Computer Software Download Link | 11 |
| Serial User Command | 11 |
| PC software operation manual | 12 |
| Correct Placement Mode of the soldering iron | 16 |
| Connecting mode | 17 |
| Replacement of Heating Core | 18 |
| Replacement of Sponge or Steel Wool | 20 |
| Regular Cleaning | 21 |
| Specification and Model of Product | 22 |
| Integrated Heating Core Specification | 22 |
| Daily use and maintenance | 24 |
| Care and maintenance | 25 |
| Exploded view of machine | 26 |
| Product warranty | 29 |
| After-sale contact | 29 |

Copyright Information

The design of this product (including internal software) and the accessories are protected by relevant laws of China. Any violation of relevant rights of our company will be subject to legal sanction. Please abide by relevant national laws when you use this product.

Description of Common Symbols

Thank you for using our products. Before using this product, please read this Manual carefully and pay attention to the warnings and cautions mentioned herein.

| | |
|---|---|
|  | Alerts you against possible electric shock. |
|  | Alerts you against possible bodily injury. |

Essentials for Users

User should have basic knowledge of life and basic electrical operation before using the product. Underage user can only use this product under the guidance of a professional or guardian.

[Note]: In order to avoid damage to the machine and keep the operating environment safe. Please read this Manual carefully before using this product, and keep it properly for future reference.

Safety Cautions

You must observe the following basic items while using this machine to avoid electric shock, bodily injury, fire or other hazards. In order to ensure personal safety, only the parts and accessories accepted or recommended by the original manufacturer can be used, otherwise it will lead to serious consequences!

WARNING

- Please make sure that the ground wire of power cord is grounded reliably when using the machine;
- DO NOT use the hot air nozzle directly on any person or animal. No matter under any circumstance, it is strictly prohibited to use the hot air gun as a hair dryer. DO NOT touch the heating pipe or blow the skin directly with the hot air gun;
- Please use the hot air gun with care. Do not drop or violently shake the machine. Do not put heavy materials on the equipment, or roughly operate the machine;
- The temperature will differ for different nozzle models which is a normal phenomenon, and is not a quality issue of the equipment;
- Do not use the machine with wet hands, or when the electric wire is damp to avoid short circuit or electric shock hazard;
- Keep this product away from children;
- DO NOT use this product near flammable gases or other flammable substances;
- Please use the spare parts provided by the manufacturer. The machine will not be covered by quality warranty service if any non-original accessory is used;
- DO NOT touch the soldering tip, desoldering nozzle, air nozzle and surrounding metal parts;
- Before replacing a component or soldering tip, desoldering nozzle or air nozzle, turn off the power and operate after the equipment is cooled;
- Do not use this equipment for any purpose other than desoldering;
- Fume will be generated upon soldering, so please provide ventilation measures;
- Do not play around when using the equipment, which may easily lead to physical injury;
- When using the equipment, please pay attention to the power specification;
- After use, please turn off the power switch, and the equipment will automatically shuts down once the blast cools off.

Disclaimer

The company assumes no liability for personal injury or property loss arising from failure to follow relevant instructions, natural disasters and other force majeure or personal failures or other failures other than product nonconformity.

This Manual is collated, compiled and issued by ATTEN according to the latest product features. The product and this Manual may be subject to subsequent updating without prior notice.

[Note:] In order to avoid damage to the machine and keep the operating environment safe. Please read this Manual carefully before using this product, and keep it properly for future reference.

Exploded view of the Bottom case assembly

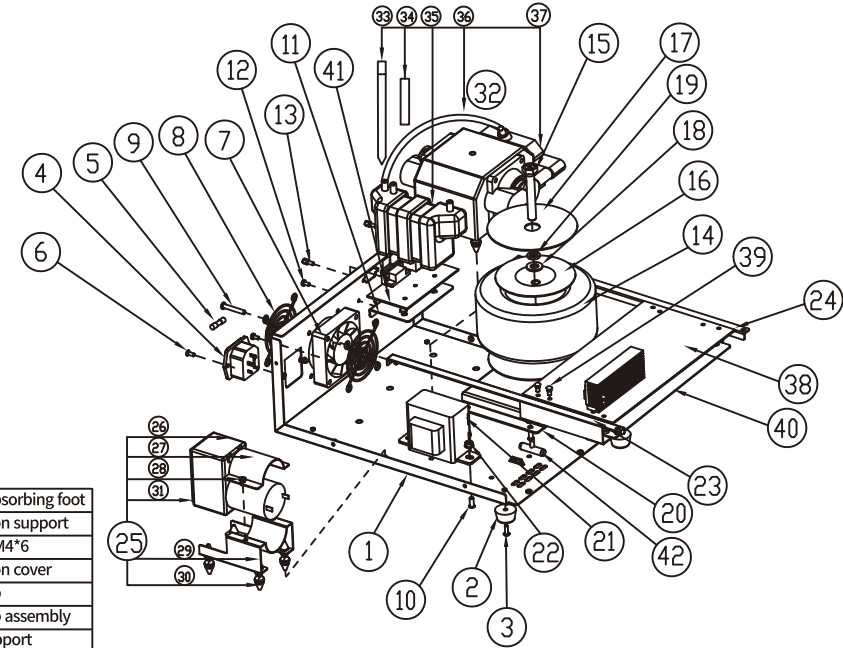

| | | | |
|------------|---------------------------------------|----|--|
| 30 | Shock-absorbing foot | | |
| 29 | Air suction support | | |
| 28 | Screw PM4*6 | | |
| 27 | Air suction cover | | |
| 26 | Air pump | | |
| 25 | Air pump assembly | | |
| 24 | Right support | | |
| 23 | Left support | | |
| 22 | M4 flange nut | | |
| 21 | Transformer 1 | | |
| 20 | Transformer mounting plate | | |
| 19 | Spring washer | | |
| 18 | Washer | | |
| 17 | Rubber washer on toroidal transformer | | |
| 16 | Steel cover on toroidal transformer | | |
| 15 | Hexagon bolt M8*65 | | |
| 14 | Transformer 1 | | |
| 13 | Hexagon stud #4-40*5+7mm | | |
| 12 | Screw PM3*6 | 42 | Three-way joint |
| 11 | Communication board mounting plate | 41 | Communication board |
| 10 | Nut M4 | 40 | PVC insulation film |
| 9 | Screw PM4*25 | 39 | PC board spacer support |
| 8 | Fan mesh enclosure | 38 | PCBA Power board |
| 7 | Fan | 37 | Air pump |
| 6 | Screw KM3*8 black | 36 | Highly Tear resistant silicone rubber pipe |
| 5 | Fuse 5A Φ5*20 | 35 | Air storage tank |
| 4 | Power Outlet | 34 | Double-side foam paper |
| 3 | Screw PWM4*10 | 33 | Cable ties 8*500 |
| 2 | Rubber undercarriage | 32 | Air pump assembly |
| 1 | Bottom case | 31 | Foam |
| Serial No. | Material name | | |

Exploded view of the MS-900 host

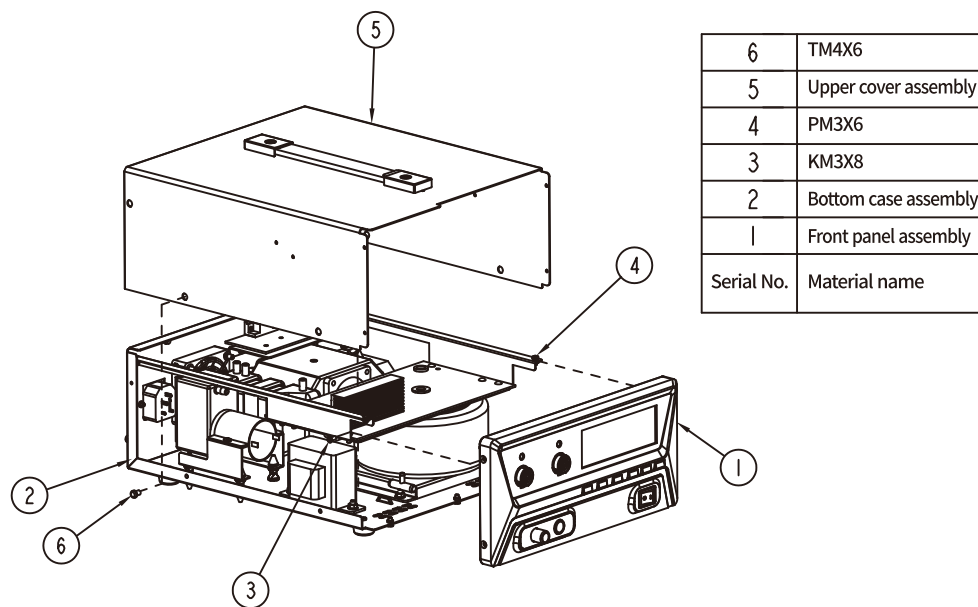

| | |
|------------|----------------------|
| 6 | TM4X6 |
| 5 | Upper cover assembly |
| 4 | PM3X6 |
| 3 | KM3X8 |
| 2 | Bottom case assembly |
| 1 | Front panel assembly |
| Serial No. | Material name |

Exploded view of the Front panel assembly

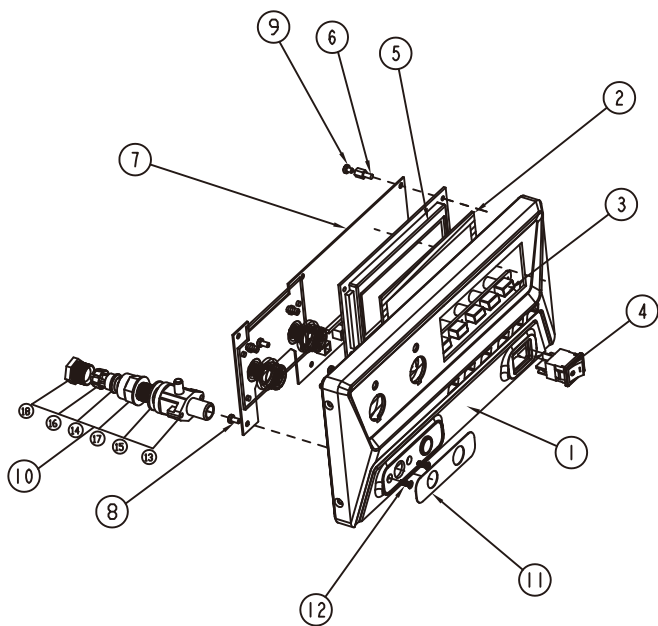

| | |
|------------|--------------------------|
| 18 | Sealing nut |
| 17 | Sealing threaded sleeve |
| 16 | Locking ring |
| 15 | Three-way joint seal |
| 14 | Washer |
| 13 | Three-way joint |
| 12 | KA3*10 screw |
| 11 | Decoration panel |
| 10 | Three-way joint assembly |
| 9 | PM3X4 |
| 8 | PM3X6 |
| 7 | PCBA of front panel |
| 6 | Copper stud |
| 5 | LCD |
| 4 | Switch |
| 3 | Button |
| 2 | Display lens |
| 1 | Front panel |
| Serial No. | Material name |

Packing List

| | | | | | |
|----|----------------------|--------|----|------------------------------|--------|
| 1 | Main unit | 1 set | 13 | Rubber washer | 2 pcs |
| 2 | Hot air gun | 1 pc | 14 | Desoldering nozzle | 3 pcs |
| 3 | Soldering iron stand | 2 pcs | 15 | Nozzle | 4 pcs |
| 4 | Soldering pen | 1 pc | 16 | Desoldering gun front plug | 2 pcs |
| 5 | Electric tweezers | 1 pc | 17 | Desoldering gun O-ring 6x1.5 | 2 pcs |
| 6 | Desoldering gun | 1 pc | 18 | Desoldering gun O-ring | 2 pcs |
| 7 | Suction pen | 1 pc | 19 | Desoldering tube liner | 1 pc |
| 8 | Power cord | 1 pc | 20 | Filter cotton | 10 pcs |
| 9 | Blow-dryer bracket | 1 pc | 21 | Dust-absorbing sponge | 10 pcs |
| 10 | Screw | 2 pcs | 22 | Spring pin (cleaning pin) | 1 pc |
| 11 | Suction disk | 11 pcs | 23 | Anti-ironing mat | 1 pc |
| 12 | Suction nozzle | 3 pcs | 24 | User Manual | 1 pc |

Product Overview

MS-900 is a 4 in 1 Rework Station integrated with hot air gun, soldering gun, desoldering gun and electric tweezers. Three tool channels can be used independently without interference. It adopts integrated and streamline design which has saved the operating space. Large LCD screen can display various information clearly. It is a perfect assistant of labs, technical personnel and electronics engineer.

※ In order to avoid damage to the machine and keep the operating environment safe. Please read this Manual carefully before using this product, and keep it properly for future reference.

Functional Features

- High accuracy MCU control is employed to synchronously detect whether the 3 tool channels can be used independently and synchronously without mutual interference.
- Built-in vacuum generator.
- Super power. The whole machine can provide a maximum of 900W power output.
- Stand-alone machine can carry out multiple desoldering tasks simultaneously.
- Large screen graphics display screen which can display all kinds of parameter data and messages graphically. The contents can be presented abundantly and intuitively.
- Automatically identify all kinds of welding tools and load corresponding parameters.
- The software can adjust the temperature automatically which is more accurate and convenient.
- Fault display and alarm functions available.
- Functions such as standby, beep alarm, temperature lock and factory data reset available.
- Support communication interface. It can access to a computer, and complete various settings following the specified program.
- Vacuum desoldering pen is added to facilitate dismantle the desoldering components.

Soldering pen

- The soldering station adopts integral heating core material which provides thermal conduction and extremely high temperature returning speed. It only needs 8s to heat up the room temperature when the machine is started up to 350 C.
- Front sensor is adopted to ensure high temperature control accuracy and good temperature stability.
- The welding holder is light and comfortable.

Electric tweezers

- The heating core of electric tweezer adopts 12VDC low-voltage power supply and the main power transformer isolation output which is safe and reliable.
- Front sensor is adopted to ensure high temperature control accuracy and good temperature stability.

Desoldering gun

- The heating core of desoldering station adopts 24VDC low-voltage power supply and the main power transformer isolation output which is safe and reliable.
- Built-in vacuum pump with strong suction.

Hot air gun

- Intelligent cooling system is adopted. It can automatically delay the air supply when the equipment is shutdown which can greatly extend the service life of the heating core and holder.
- Spiral heating core is adopted which can contribute to longer service life.
- The holder of hot air gun has been redesigned to make the air more even. It is not easy to damage which is convenient for maintenance, storage and transportation.

Specifications and Parameters

| | | | | |
|--------------------------------|---|---|---|---|
| Input power | 230VAC 50Hz (optional 110VAC 60Hz) | | | |
| Total power | 900W (max) | | | |
| Name | AP-552B Hot air desoldering station | GT-Y130 Soldering pen | GT-X150 Desoldering gun | GT-N100 Electric tweezers |
| Power | Heating component 550W, air pump 25W | 130W | Heating component 150W, vacuum pump 15W | 100W |
| Output power | The same with the input power | 24VDC | 24VDC | 24VDC |
| Temperature range | 150-500°C/ 302-932°F | 150-500°C/ 302-932°F | 300-500°C/ 572-932°F | 150-500°C/ 302-932°F |
| Standby temperature | No standby | 200°C | 300°C | 200°C |
| Standby time | NA | 1-120 minutes (0 means standby deactivated) | 1-120 minutes (0 means standby deactivated) | 1-120 minutes (0 means standby deactivated) |
| Air flow | 23L/min(Max) 5L/min(Min) | NA | NA | NA |
| Noise | <52 dB(A) | NA | NA | |
| Temperature adjusting range | -50~+50°C/-90~+90°F | | | |
| Lock setting | Available | | | |
| Temperature stability | ±5°C | ±2°C | ±2°C | ±2°C |
| Tip to ground impedance | <2 Ohm | | | |
| Tip to ground voltage | <2 mv | | | |
| Working Temperature & Humidity | Temperature 0°C ~ 40°C Relative humidity < 80% | | | |
| Storage Temperature & Humidity | Temperature -20°C ~ 80°C Relative humidity < 80% | | | |
| Overall dimension | 310(L)x309(W)x146(H)mm (with hot air gun holder) | | | |
| Weight | 8270 g (Main unit + Power cable + Hot air gun + Hot air gun holder) | | | |

※ The above specification may change. Please refer to the actual machine parameters.

Tool Kit Diagram

※ The following specification is the standard configuration of the equipment, and it also supports GT-Y050/GT-Y150 soldering pen (optional).

This product needs to be tested before shipment, so some accessories may cover a small amount of tin and the casing will be slightly yellowing, which is a normal phenomenon.

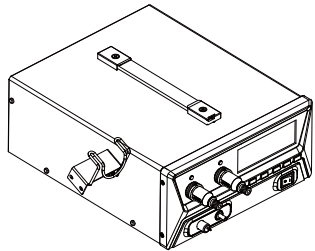

MS-900 Main unit

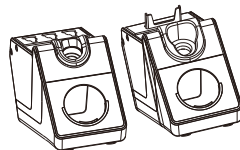

Soldering iron stand

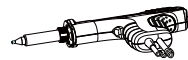

GT-X150 Desoldering gun
(for MS-900 only)



GT-B001 Suction pen



GT-Y130 Soldering pen





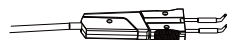





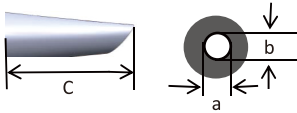

AP-552B Hot air gun

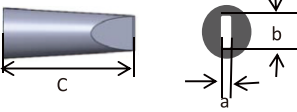

GT-N100 Electric tweezers

Care and maintenance

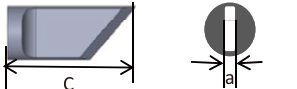
| Fault code or fault description | Likely causes of the faults |
|---------------------------------|--|
| E-1: thermal fuse fault | <ol style="list-style-type: none"> 1. In case open circuit fault occurs to the heating core, replace it. 2. In case poor contact occurs to the heating core, unplug and then re-install it. 3. In case the internal connection cable inside the heating core & handle is broken or heating core connection contact piece is damaged, repair the broken lead wire or replace the soldering pencil. |
| E-2:sensor alarm | <ol style="list-style-type: none"> 1. In case the heating core is damaged, replace it. 2. In case open circuit occurs to the lead wire of the Sensor, check the lead wire of the soldering pencil. |
| Screen display fault: | <p>In case the problem occurs, you can try to adopt the following measures to solve it. If the problem still cannot be solved, please return the equipment to the original factory for inspection.</p> <ol style="list-style-type: none"> 1. Check if the socket switch is on. 2. Check if there is voltage on the socket. 3. Check if the plug with the power line is loose. 4. Check if the fuse is damaged (if so, please replace the fuse according to the specifications) |
| Inaccurate temperature: | <ol style="list-style-type: none"> 1. Use user temperature compensation function to correct the temperature. 2. Replace the heating core with one produced and sent by the original factory. |
| Mojibake: | <ol style="list-style-type: none"> 1. In case there is strong interference source from the outside environment, please change the application environment or evacuate from the interference area. 2. In case the internal circuit is abnormal, please send the equipment to the designated after-sales outlet for maintenance. |

| T150 series (applicable to GT-Y150 soldering iron) | | | | | |
|---|---|-----------|-------------|------|------|
| Bevel soldering tip (type C)  | Graphical representation | Model | Φ a mm | b mm | c mm |
| |  | T150-3C | 3.0 | 3.0 | 15 |
| |  | T150-5C | 5.0 | 5.0 | 16 |
| |  | T150-6.5C | 6.5 | 6.5 | 16 |
| Chisel-like soldering tip (type D)  | Graphical representation | Model | Φ a mm | b mm | c mm |
| |  | T150-3.2D | 1.2 | 3.2 | 13 |
| |  | T150-4.6D | 1.6 | 4.6 | 13 |
| |  | T150-6.5D | 2.0 | 6.5 | 13 |
| Knife-like soldering tip (type K)  | Graphical representation | Model | Φ a mm | b mm | c mm |
|  | T150-K | 3.0 | | 17 | |

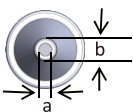
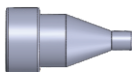
| T151 series (applicable to GT-X150 desoldering gun) | | | | |
|--|--|----------|-------------|------|
|  | Graphical representation | Model | Φ a mm | b mm |
| |  | T151-0.8 | 0.8 | 1.8 |
| | | T151-1.0 | 1.0 | 2.0 |
| | | T151-1.3 | 1.3 | 2.3 |
| | | T151-1.6 | 1.6 | 3.0 |

Daily use and maintenance

In order to ensure service life of the product, please pay attention to the precautions during use:

- Use lower soldering temperature, excessive soldering temperature will damage the parts and the PCB, and will also oxidize the soldering tip, shortening the service life of the soldering tip.
- Use low-activity solder flux where possible. Use corrosive solder flux will shorten the service life of the soldering tip.
- Timely remove the oxidation in the soldering tip to ensure fleet soldering. Attention! Simply scrape the oxidation layer when clearing, and do not abrade the soldering tip with force, otherwise the service life of the soldering tip may be undermined.
- When wiping the soldering tip, make sure to use soft materials, e.g. wet sponge, etc. If the soldering tip is severely oxidized, steel wool can be used to wipe and clean. Attention! Regularly use steel wool to wipe the soldering tip may influence the service life of the soldering tip.
- Upon heating, please make sure that the soldering tip is tinned, so as to prevent oxidation.
- Upon soldering, please do not exert great force in the soldering tip, otherwise it will not be helpful to melt the soldering tin, but will damage the soldering object and the heating core.
- When using the GT-X150 holder, do not suck any other materials other than soldering tin, to avoid damage to the main unit.

Front Panel Interface Diagram

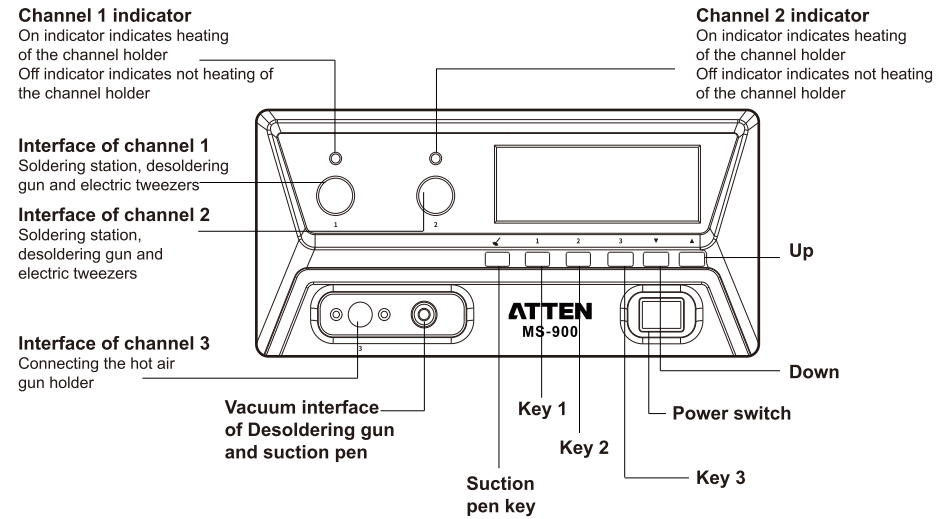

Rear Panel Interface Diagram

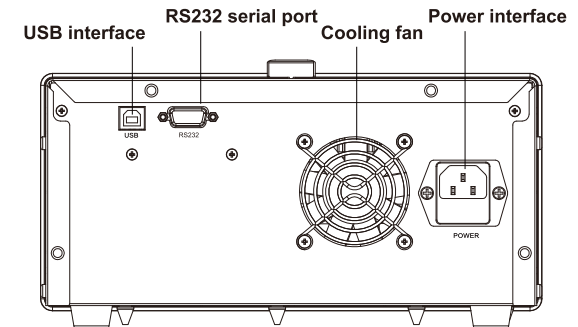

Work Interface Description

After the machine is powered on, turn on the power switch. The screen will display the company name for 3s and then switch to the normal working interface.

Boot screen of MS-900



Working Interface Introduction and Operation Method

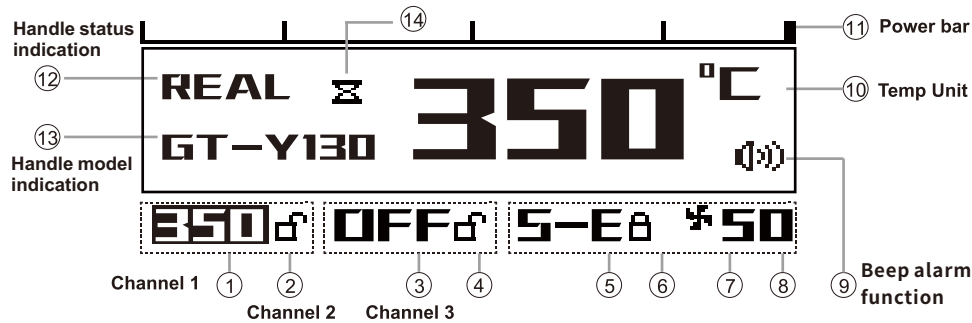

※ When the desoldering gun fails to reach the setting temperature, displays "⊠"; When the desoldering gun is blocked, displays "🔒"; In other statuses, provides no indication.

Channel 1

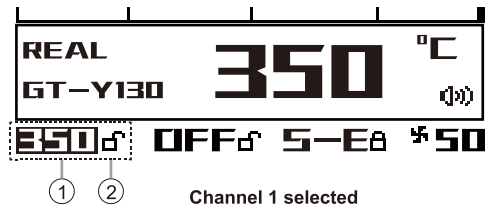

① **Inverse selection indicates that the current channel is selected.**

Long press key "1" to turn on/off channel 1.
 Channel 1 off: Always shows OFF.
 Channel 1 open:
 Selected: Always show temperature setting values
 Unselected, display according to the running state.

| Running state | Display contents |
|---------------------------------------|---------------------|
| Normal operation | Setting temperature |
| Standby | SLP |
| Sensor failure or no handle available | S-E |
| Heating core damage | Display H-E |

Short press key 2 (or 3) to switch to the Channel 2 (or 3). And the channels switched will be in Invert Selection state.

- ② Channel 1 locking: When it is unlocked, and press the "▼" "▲" on the panel to increase or decrease the parameter value. When it is locked, the channel parameters cannot be changed.
 Channel 1 locking on/off: Press "🔒" for more than 3s to switch the locking function between on and off.

T100 series (applicable to GT-N100 tweezers)

| Chisel-like soldering tip (type D) | Graphical representation | Model | Φ a mm | b mm | |
|-------------------------------------|--------------------------|-----------|--------|------|--|
| | | T100-1.3D | 0.5 | 1.3 | |
| | | T100-2.2D | 0.5 | 2.2 | |
| | | T100-3.0D | 1.0 | 3.0 | |
| Conical-like soldering tip (type I) | Graphical representation | Model | Φ a mm | | |
| | | T100-0.5I | 0.5 | | |









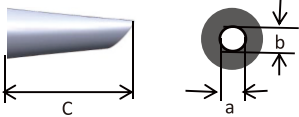

T130 series (applicable to GT-Y130 soldering iron)

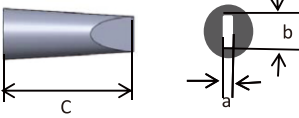
| Bevel soldering tip (type C) | Graphical representation | Model | Φ a mm | b mm | c mm |
|-------------------------------------|--------------------------|-----------|--------|------|------|
| | | T130-1.2C | 1.2 | 1.2 | 10.0 |
| | | T130-2.4C | 2.4 | 2.4 | 10.0 |
| | | T130-3.2C | 3.2 | 3.2 | 10.0 |
| | | T130-4.6C | 4.6 | 4.6 | 10.0 |
| Chisel-like soldering tip (type D) | Graphical representation | Model | Φ a mm | b mm | c mm |
| | | T130-1.6D | 0.8 | 1.6 | 10.0 |
| | | T130-2.4D | 1.0 | 2.4 | 10.0 |
| | | T130-3.2D | 1.2 | 3.2 | 10.0 |
| | | T130-4.6D | 1.6 | 4.6 | 10.0 |
| Conical-like soldering tip (type I) | Graphical representation | Model | Φ a mm | b mm | c mm |
| | | T130-0.5I | 0.5 | 10.0 | |
| | | T130-1.0I | 1.0 | 10.0 | |
| Knife-like soldering tip (type K) | Graphical representation | Model | Φ a mm | b mm | c mm |
| | | T130-K | 2.0 | | 12.5 |

Specification and Model of Product

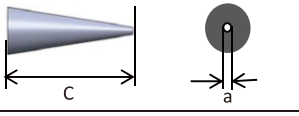
| | | | | | |
|--------------------|---------------------------------------|-------------|-----------------------|-------------|---------------------------|
| Product model | GT-Y050 (Optional) | GT-Y130 | GT-Y150 (Optional) | GT-N100 | GX-X150 |
| Rated voltage | 12VDC | 24VDC | 24VDC | 12VDC | 24VDC |
| Heating power | 50W | 130W | 150W | 50W*2 | 150W |
| Temperature range | 150-500°C ; 302-932°F | | | | 300°C-500°C ; 572°F-932°F |
| Material of cable | High temperature resistant silica gel | | | | |
| Heating core type | Integrated heating element | | | | |
| Temperature sensor | Thermocouple | | | | |
| Heating core model | T50 series | T130 series | T150 series | T100 series | GX-X150 |

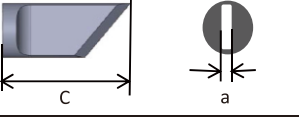
Integrated Heating Core Specification (For option)

| T50 series (applicable to GT-Y050 soldering iron) | | | | | | |
|---|---|----------|-----------|---------|---------|--|
| Bevel soldering tip (type C) | Graphical representation | Model | Φ a mm | b mm | c mm | |
|  |  | T50-1.2C | 1.2 | 1.2 | 9.0 | |
| Chisel-like soldering tip (type D) | Graphical representation | Model | Φ a mm | b mm | c mm | |
|  |  | T50-1.3D | 0.5 | 1.3 | 9.0 | |
| |  | T50-2.2D | 0.5 | 2.2 | 9.0 | |
| |  | T50-3.0D | 1.0 | 3.0 | 9.0 | |
| Conical-like soldering tip (type I) | Graphical representation | Model | Φ a mm | | c mm | |
|  |  | T50-0.5I | 0.5 | | 9.0 | |
| Knife-like soldering tip (type K) | Graphical representation | Model | Φ a mm | | c mm | |
|  |  | T50-K | 1.2 | | 9.0 | |

Channel 2

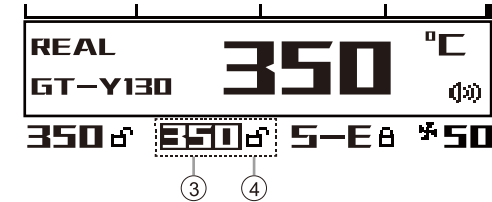

Channel 2 selected

* Operation same with that of channel 1

- ③ Long press key "2" to turn on/off channel 2. Short press key "1" (or key "3") to switch to channel 1 (or channel 3), and the channels switched will be in Invert Selection state. Operation is the same with that of channel 1
- ④ Channel 2 lock symbol.

Channel 3

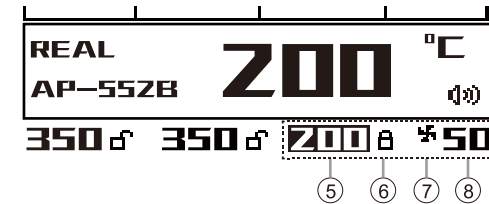

Channel 3 selected

* Operation same with that of channel 2

- ⑤ Long press key "3" to turn on/off channel 3. Short press "3" to switch between temperature or air flow settings Short press key "1" (or key "2") to switch to channel 1 (or channel 2), and symbol is in reverse selection, it means that it is in air volume adjustment state.
- ⑥ Channel 3 lock symbol.
- ⑦ When the fan symbol is displayed, it means that it is in air output state; inverse selection indicates air flow adjustment status.
- ⑧ Air volume display of Channel 3



Beep alarm function

- ⑨ When the tone function symbol is on, keypad tone will appear at all keys operation, and will disappear after turn it off. When the power switch is off, long press "▼" and "▲" key. Turn on the power switch once more to switch tone on and off.



Tone function

- ⑩ Temp Unit displayed: °C or °F
When the power switch is off, long press " ", and then turn on the power switch. The temperature unit will switch between °C and °F.

Power bar

- ⑪ Displays current channel output power status.

Holder status indication

- ⑫ Holder status indication: REAL (real-time value).

Holder model indication

- ⑬ Holder model indication NO TOOL (current channel not connected with holder), GT-Y130, GT-X150, GT-N100, AP-552B.

Other running status display



Channel 1 is selected and is working normally
Channel 2 is off
Channel 3: Sensor failure or no holder available



Channel 1 is off
Open the Channel 2 and set the temperature to 200°C
Channel 3: Sensor failure or no holder available



Channel 1 is selected and is in dormant state
Channel 2 is off
Open the Channel 3 and set the temperature to 300°C



Channel 1 is selected. Sensor failure or no holder available
Channel 2 is off
Channel 3: Sensor failure or no holder available

GT-X150 Regular Cleaning

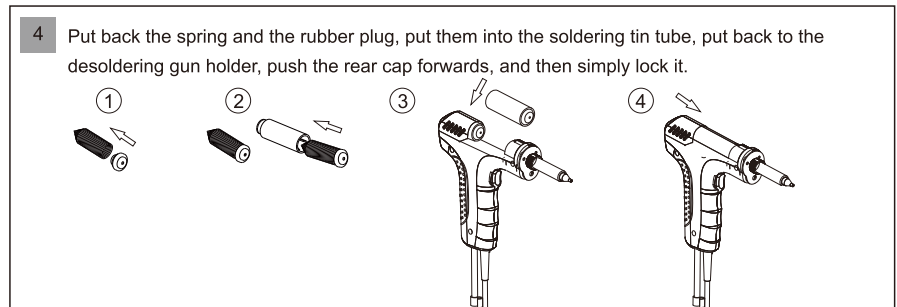
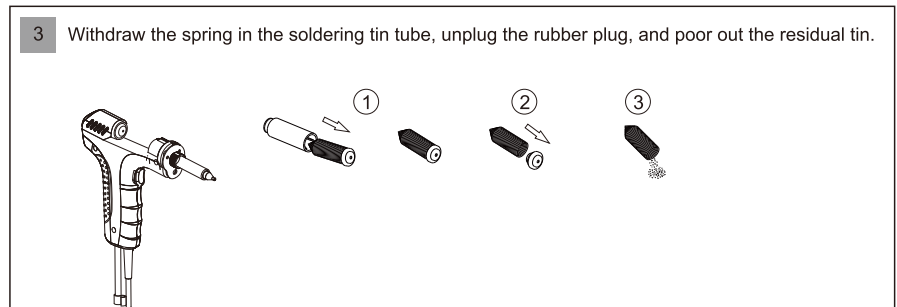
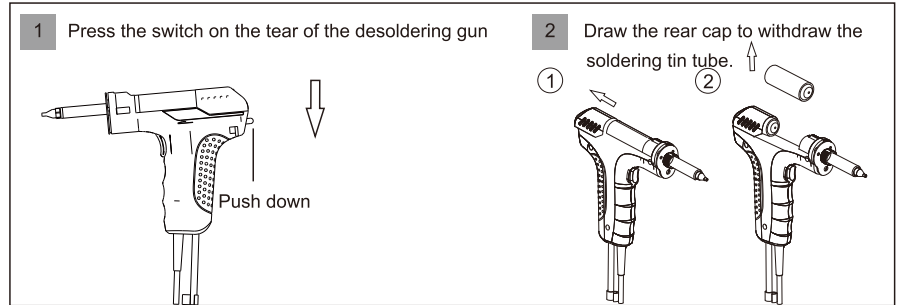

Use method of vacuum pen

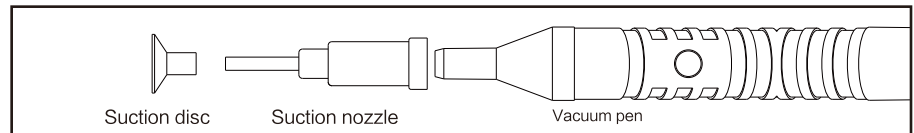

Insert the head of the suction nozzle in to the hole of the suction disc, and finally insert the vacuum pen to the end of the nozzle to complete the assembly.

GT-X150 desoldering gun heating core replacement

1 Remove the three screws on the front of the heating core, and withdraw the heating core.

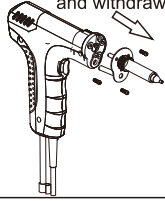

2 Put the heating core back to the holder, and lock the screws.

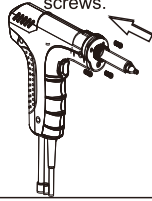

3 Placement mode of heating core .



Tips: After replacement of heating core, please verify the temperature accuracy, and use temperature compensation setting items to compensate and calibrate temperature error.

Replacement of Sponge or Steel Wool

1 Open the soldering iron stand as shown in the diagram, withdraw the sponge or steel wool.

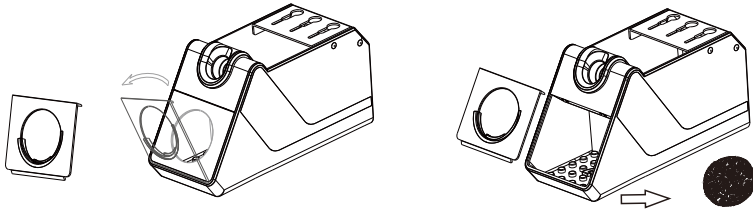

2 Put the sponge or steel wool for replacement into the soldering iron stand.

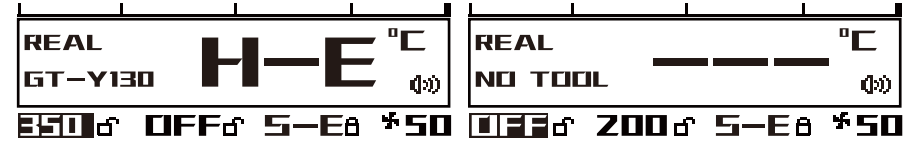
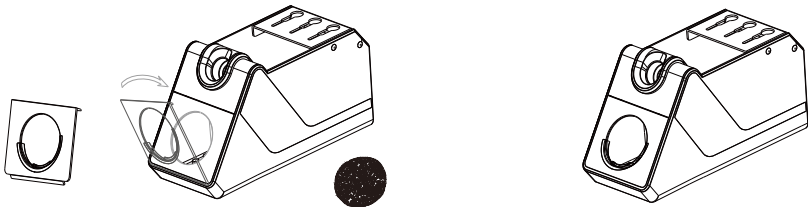

Channel 1 is selected the channel heater is damaged
Channel 2 is off
Channel 3: Sensor failure or no holder available

Channel 1 is selected. No connect handle.
Channel 2 is off
Channel 3: Sensor failure or no holder available

System Function Setting

Temperature calibration

Press key "1" to switch the channel to channel 1 of soldering station (skip this step if it is channel 1 of soldering station already). While pressing the key "1", press "1" for more than 3s to enter temperature calibration mode as shown in the figure below.

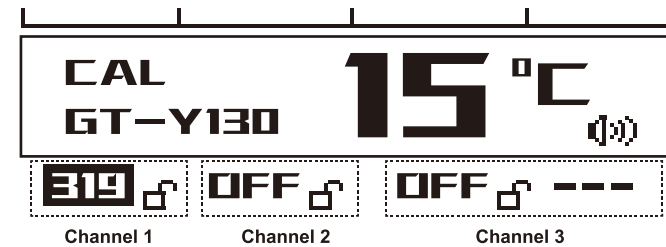

CAL Temperature calibration

Status bar displays "CAL" "GT-Y130" (current soldering iron type). The main window displays the community positive values (0°C or 0°F at delivery). Press "▼" or "▲" to enter the temperature calibration value, and press "1" to save the value. And then it will enter sleep time adjustment mode. If sleep time doesn't need to be adjusted, it will exit automatically 5s later.

Calibration method: Prepare the temperature tester. When the machine is in constant temperature, measure the temperature of the soldering iron nozzle to be corrected and keep records (Please apply some soldering material on the soldering iron nozzle so that they can contact closely). Set the measuring temperature as T1 (such as 350°C) and the display temperature as T2 (such as 335°C); the temperature should be calibrated to: $T1 (350^{\circ}\text{C}) - T2 (335^{\circ}\text{C}) = 15^{\circ}\text{C}$;

Notes:

The temperature can only be calibrated in working mode; namely when there is no holder available, the temperature cannot be calibrated.
Temperature calibration of Channel 2 (or 3): The operation method is the same with that of Channel 1. That is, switch to the channel required for temperature calibration and then conduct corresponding operation.

Sleep time setting

After temperature calibration, it will directly enter sleep time setting, or press "1" after entering the temperature calibration mode to enter sleep time setting mode. The status bar will show "SLP" "GT-Y130" (current holder model). The main window will show the sleep time (default value at delivery is 0 minute, no sleep). Press "▼" or "▲" key to enter sleep time. Press "1" to save the setting.



SLP sleep setting dialog (10minutes sleeping duration in the above figure. If the soldering station is not used within 10 minutes, the electrical soldering station will automatically enter into sleeping state.)



SLP sleeping status indication window (sleeping temperature drops to 200°C when the setting value is higher than 200°C).



SLP sleeping status indication window (sleeping temperature keep to setting value when the setting value is less than 200°C).

Sleep awakening: When Channel 1 is an electrical soldering station, and if the electrical soldering station needs to be re-started in sleep mode, press "1" to enter normal working status.

Notes:

Sleep setting of Channel 2: The operation method is the same with that of Channel 1. That is, switch to the channel required for sleep setting and then conduct corresponding operation.

Restore factory settings

When the power switch is off, long press "▼" and "▲", and then turn on the power switch to restore factory settings.

GT-Y130 GT-Y150 soldering iron heating core replacement

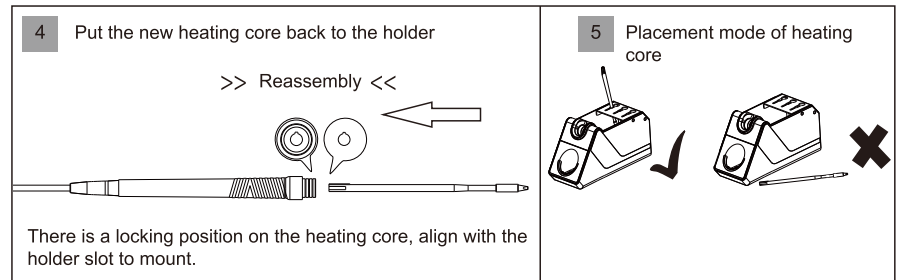
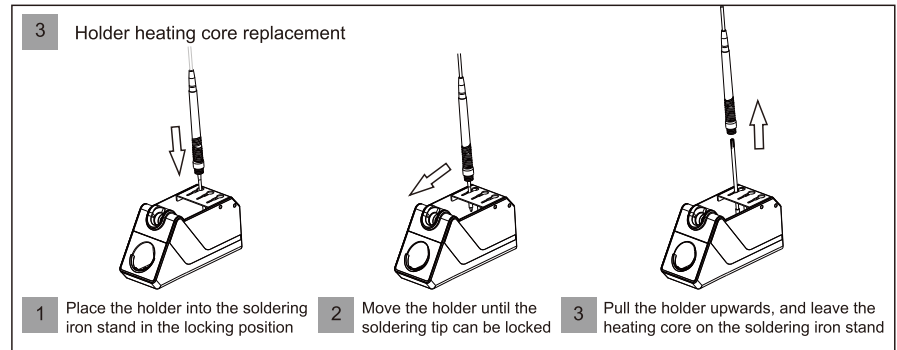

GN-N100 tweezers heating core replacement

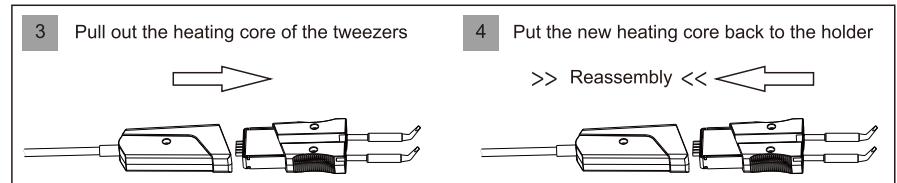

Tips: After replacement of heating core, please verify the temperature accuracy, and use temperature compensation setting items to compensate and calibrate temperature error. Do not directly place the uncooled heating core on the workbench, to avoid scald or fire.

GT-X150 desoldering gun desoldering nozzle replacement

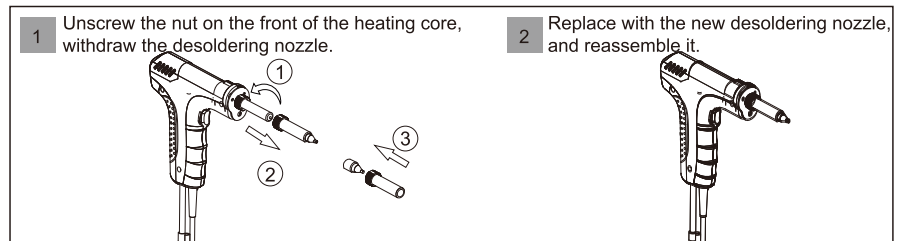

Replacement of Heating Core

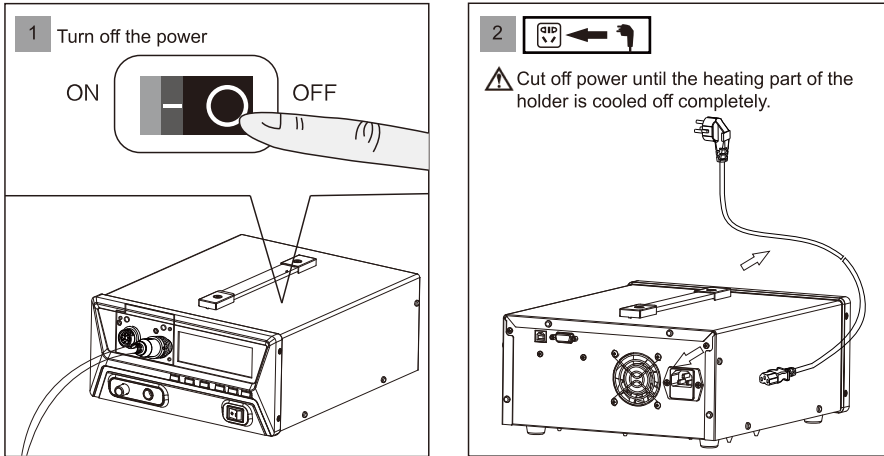

GT-Y050 soldering iron heating core replacement

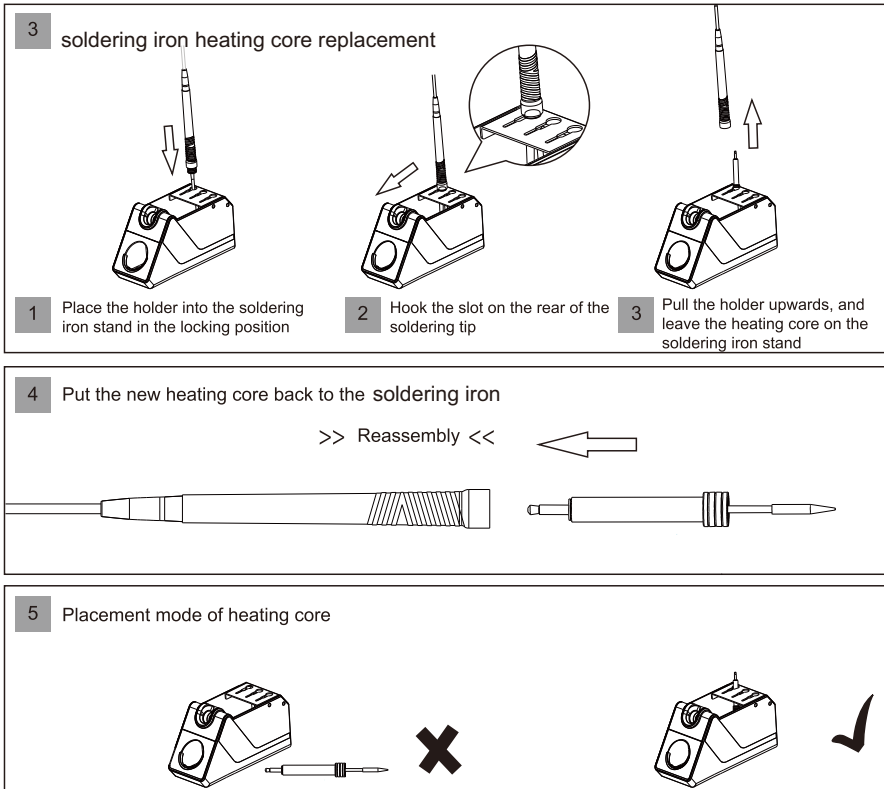

Main unit computer software download link

[www.atten.com\(EN\)](http://www.atten.com(EN))
[www.atten.com.cn\(CN\)](http://www.atten.com.cn(CN))

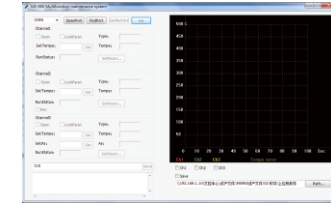

Serial user command (Main unit computer software shall be equipped)

1. c?0 Help
2. C00 Restore factory settings
3. C10 Check the temperature of all channels
 C11 Check the temperature of Channel 1
 C12 Check the temperature of Channel 2
 C13 Check the temperature of Channel 3
4. C20 Open all channels
 C21 Open Channel 1
 C22 Open Channel 2
 C23 Open Channel 3
 C24 Open desoldering pen
5. C30 Close all channels
 C31 Close Channel 1
 C32 Close Channel 2
 C33 Close Channel 3
 C34 Close desoldering pen

Indicates the data to be filled in by the user, _ indicates no need of filling

6. C41 Temperature unit selection °C 0; °F 1
- C42 Tone switch On 0; Off

If the input value has less than 3 digits, use 0 to supplement;

7. C51 Temperature value setting of Channel 1 (150 - 500°C/302 - 932°F)
 C52 Temperature value setting of Channel 2 (150 - 500°C/302 - 932°F)
 C53 Temperature value setting of Channel 3 (150 - 500°C/302 - 932°F)
 C54 Air flow value setting of Channel 3 (150 - 500°C/302 - 932°F)
8. C61 Temperature calibration value of Channel 1(-50 - 50°C/-90 - 90°F)
 C62 Temperature calibration value of Channel 2(-50 - 50°C/-90 - 90°F)
 C63 Temperature calibration value of Channel 3(-50 - 50°C/-90 - 90°F)
9. C71 Sleep time setting of Channel 1 (0 - 120)(default value at delivery is 0 minute, no sleep)
 C72 Sleep time setting of Channel 2 (0 - 120)(default value at delivery is 0 minute, no sleep)
10. C80 Parameter locking for all channels Unlock 0 Lock 1
 C81 Parameter locking for Channel 1 Unlock 0 Lock 1
 C82 Parameter locking for Channel 2 Unlock 0 Lock 1
 C83 Parameter locking for Channel 2 Unlock 0 Lock 1

1. Software running system

The PC software can be used under the following operating systems: win XP win 7 win 10

2. Interface description

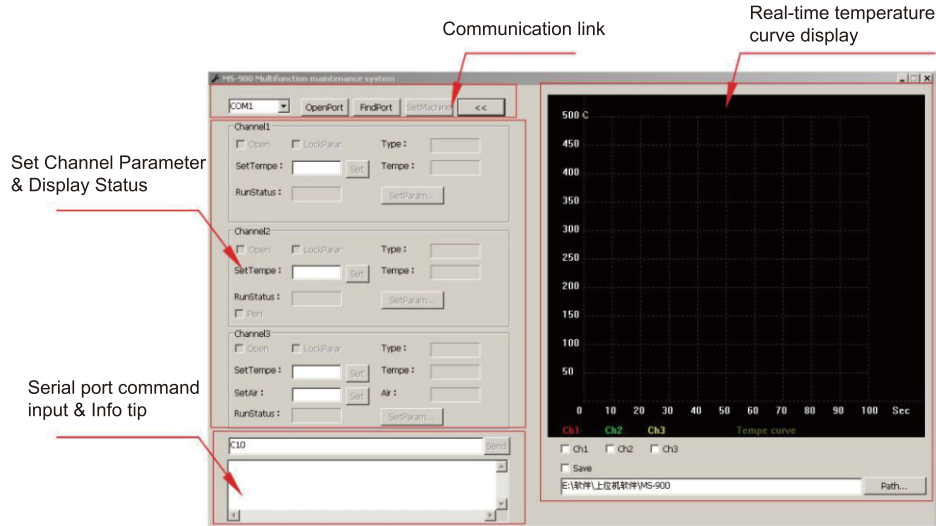

Software interface include four function modules

1. Communication module: Display communication port, automatic search port and automatic connection, communication switch, unfold and hidden real-time communication curve.
2. Channel parameter setting and status display module: Display real-time parameters information of each channel and parameter settings.
3. Serial port command input / info tip module: Input serial command manually (serial command to see the instructions on page 11) and info tip, including errors, important operating hints, etc.
4. Real-time temperature curve display module: Select real-time temperature curve chart of each channel .

Connecting Mode

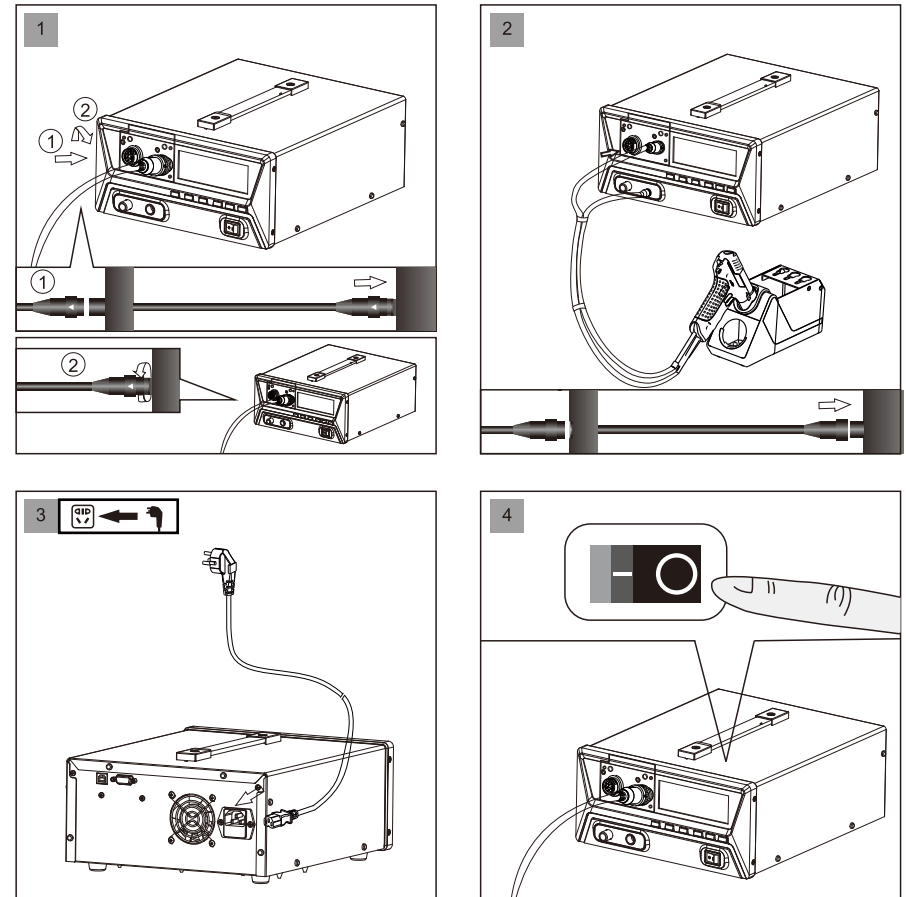

⚠ Notes:When plugging and unplugging during soldering, do remember to cut off power, so as to avoid damage to the main unit !

Anti-ironing mat

If you need to change the heater, soldering tip or suction nozzles without knowing the heating situation, you can use the anti-hot pad to change them. In case of non-emergency, it is recommended to replace the accessories after the temperature drops back to normal temperature to avoid burns.

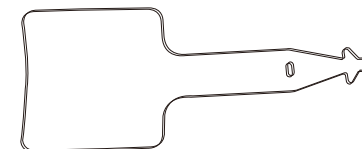

Correct Placement Mode of the soldering iron

Warning: For the sake of your safety, when the product is not in use, please place the holder to the corresponding stand.

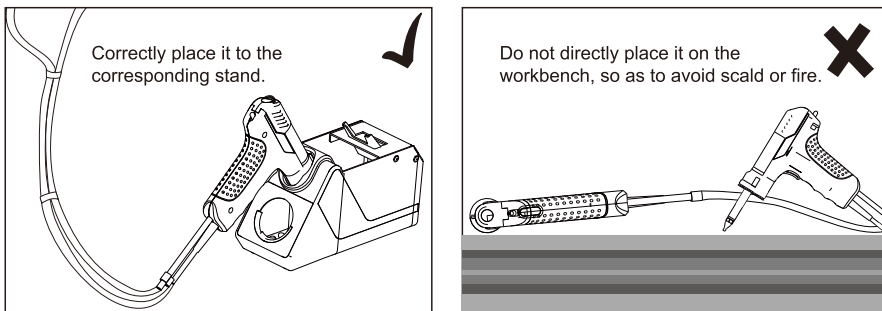
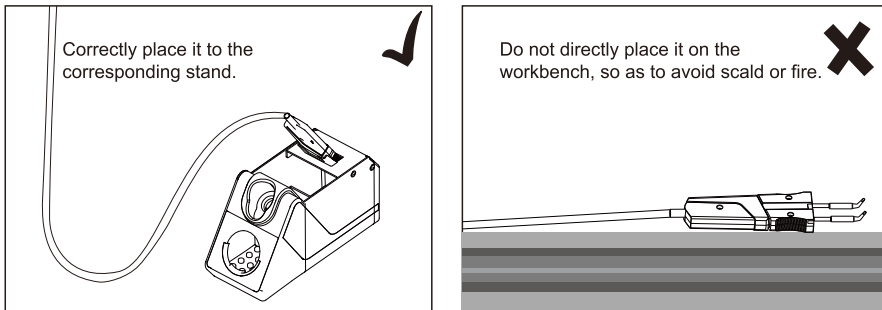
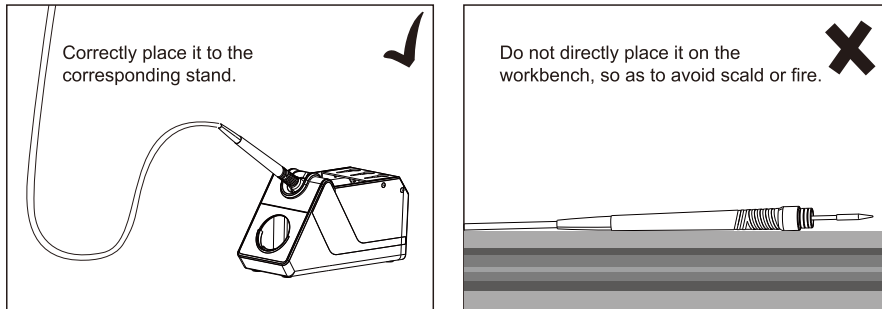

3. Operation Instruction

1. Double-click the icon (right click + open file) to open the MS - 900 PC software .
 2. Click FindPort , Software search port and connect device automatically, click Close to close the connection. (figure 1)
- Click SetMachine to set buzzer, temperature unit, factory default setting. (figure 2)
- Click << to open or close the right side of real-time curve and read-write data module.

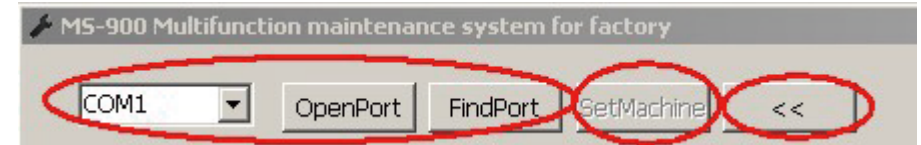

figure 1

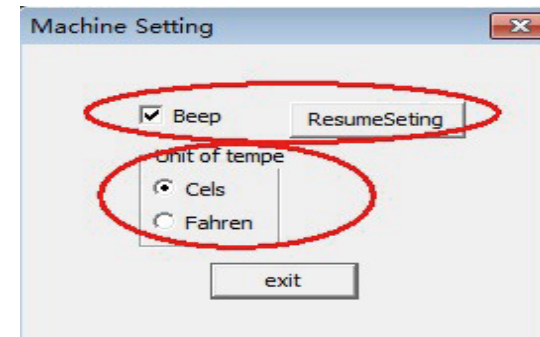
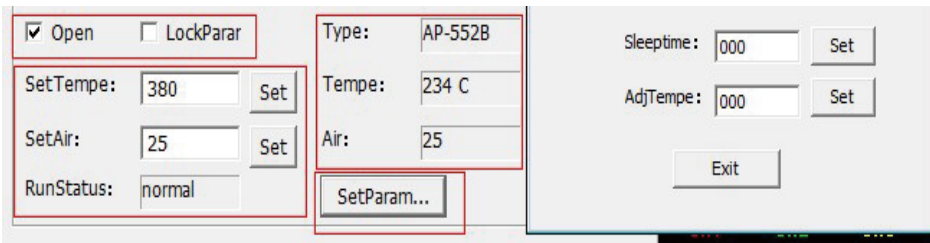
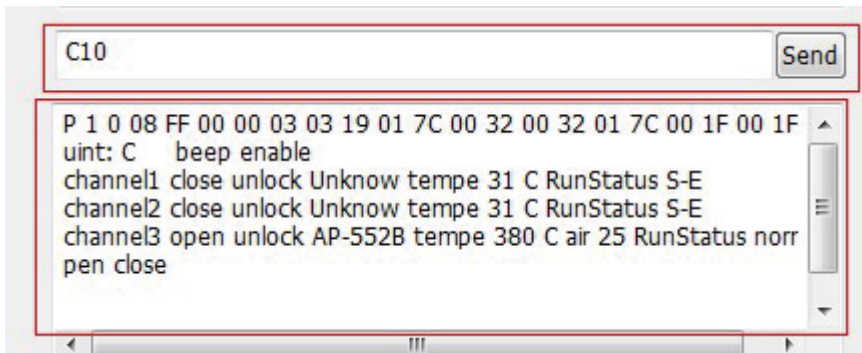

figure 2

3. Tick Open to open the channel, Tick LockParar to lock the channel temperature .
 SetTempe area set handle temperature value (150 °C -- 480 °C) for the channel .
 SetAir area set air volume for hot air gun (No air volume setting function in soldering iron channel).
 RunStatus display the real-time status of equipment operation (normal work display Normal, no soldering iron display S-E, auto-sleep display SLP, channel off display OFF).
 Type display the handle type of channel; Tempe display the temperature value of the handle; Air display the Air volume value.
 Click SetOararm , set auto-sleep time and temperature compensation , need 3 digits to display , so when set the auto- sleep time or temperature to "10", you have to input "010".



4. Area 1 can be manually entered in a serial command (specific serial command to see the instructions on page 11), click Send, info tip appears in the message box of area 2.
 Note: Message box display a variety of operation info tip and error info (alarm message).



5. CH1 ,CH2 and CH3 means of different channel , Click it and display the real-time temperature curve of each channel in the above areas.
 Click Path , set save address of the real-time temperature curve, Click Save , real-time temperature curve save as excel form file to the setting address.

